

For the lifting use n° 2 eyebolts M10
Lifting points are designed for actuator only

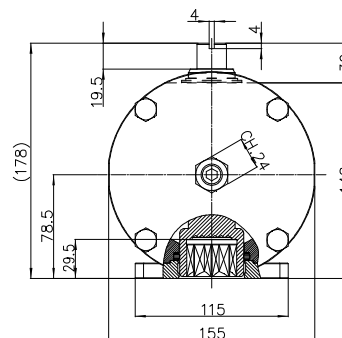

Function



Double Acting Actuators - Output Torque related to rotation angle , in Nm (0°valve closed 90°valve open)

ROTATION ANGLE	Air pressure supply in bar							
	2,5	3	4	5	5,6	6	7	8
0°	321.4	385.7	514.3	642.9	720	771.4	900	1028.6
50°	160.7	192.9	257.1	321.4	360	385.7	450	514.3
90°	241.1	289.3	385.7	482.1	540	578.6	675	771.4

Technical Data

Max Pressure	** Min Pressure	Rotation	Stroke Adjustment	Screw Stroke Adjustment	*Moving time (sec.)		Operating temperature (°C)
					Opening	Closing	
8.4 bar	1 bar	92° -1° +91°	10°	For 1° drive Need 1/2 turn screw	1	1.1	Standard -20°C +80°C High temperature -20°C +150°C Low temperature -50°C +60°C

Weight Kg	Chamber Ø (mm)	Air volume L/cycle	Maximum flange torque values
30	115	3.7	F10 = 500 Nm F12 = 1000 Nm

*The moving time could vary on different operating and installation factors.

**Attention: for "High Temperature" and "Low Temperature" version, the Min Pressure is 3.bar.

Operating Medium

The operating medium shall have a dew point equal to -20 °C or, to be at least, 10 °C below the ambient temperature (ISO 8573-1, Class 3).
The maximum particle size shall not exceed 40 µm (ISO 8573-1, Class 5).